

CAD FILE:

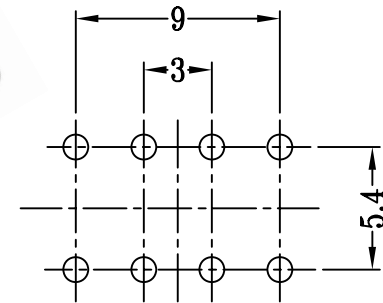
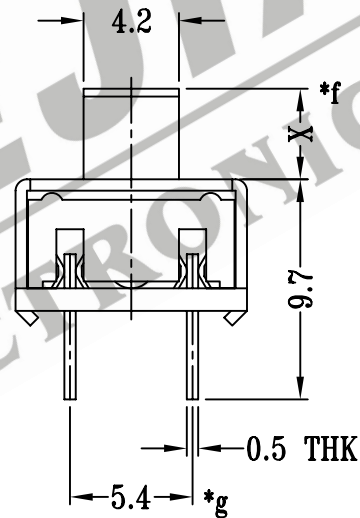
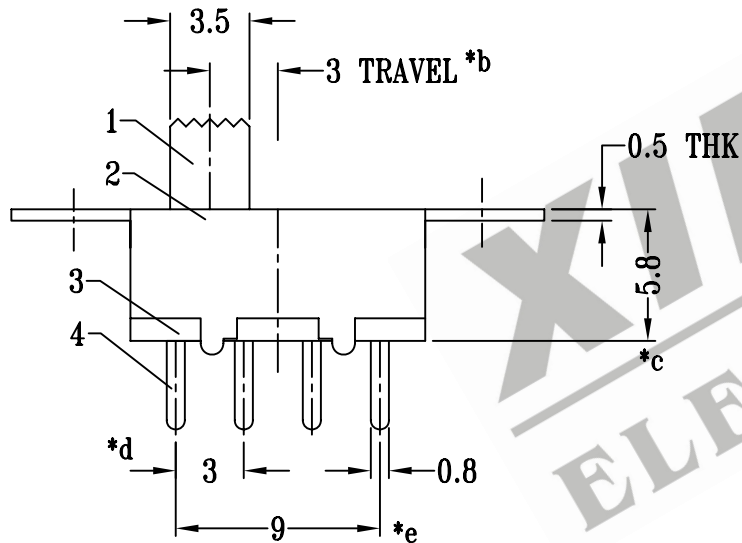
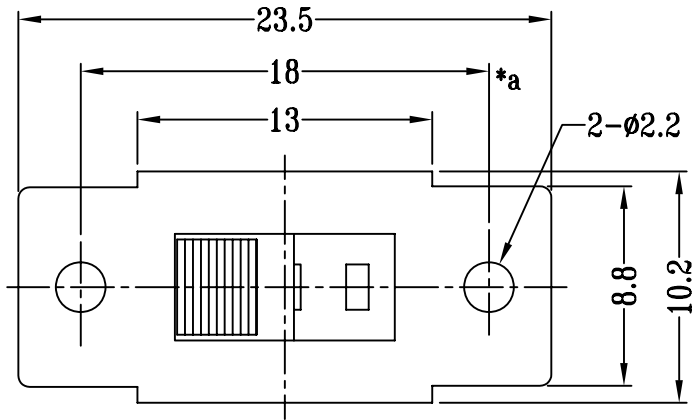

SCHEMATIC (NON-SHORTING)

P.C.B LAYOUT

注:带"*"表示关键尺寸(7个)

8					TOLERANCE UNLESS SPECIFIED	SHENZHEN XIEJIA ELECTRONICS CO.,LTD.			
7	STEEL BALL	STEEL	1	NATURAL	WITHIN: 1.5±0.1mm OVER : 1.5±0.2mm	ISSUE	DATE	DESCRIPTIONS	APPD.
6	SPRING	STEEL WIRE	1	TEMPER					
5	CONTACT CLIP	PBS STRIP	2	Ag PLATED	TITLE : VERTICAL SLIDE SWITCH				
4	TERMINAL	BRASS STRIP	8	Ag PLATED OVER Ni PLATED	UNIT : mm	DRWG NO.: XJ-DR-SS23F34-00			
3	BASE	PHENOLIC RESIN	1	NATURAL	MODEL: SS-23F34	SCALE: 3:1	DWN.	ZHOUYU	2004-11-2
2	FRAME	STEEL STRIP	1	Ni PLATED			CHK'D	FANGYING	2004-11-2
1	KNOB	POM	1	BLACK	ALL MATERIALS MUST BE COMPLIANT TO ROHS				
NO.	PART NAME	MATERIAL	Q'TY	FINISHING	APPD.	KANGXINAN	2004-11-2		